



D-CORVUS

USER GUIDE

Version 3.3

Document 23-10124

Prepared by:
DragoonITCN
900 Senate Drive
Dayton, Ohio 45459

Table of Contents

1	D-Corvus Introduction.....	2
1.1	System Description	2
1.2	Aircraft Bus testing.....	4
1.2.1	Aircraft Stub Connection.....	4
2	D-Corvus Test Procedures.....	6
2.1	Calibration.....	6
2.1.1	Calibration setup.....	6
2.2	Aircraft Test Setup	10
2.3	D-Corvus Operation	10
2.3.1	D-Corvus User Interface	10
3	D-Corvus Power Specifications	14
3.1	Front Panel Indicators.....	14
3.2	Battery information	14

Table of Figures

Figure 1	D-Corvus Tx & Rx Box Front Panel	3
Figure 2	Aircraft Stub Connections	4
Figure 3	Insertion Loss	5
Figure 4	D-Corvus Calibration Connections	6
Figure 5	USB Splitter	7
Figure 6	D-Corvus Icon	8
Figure 7	D-Corvus Application User Interface.....	9
Figure 8	D-CORVUS UI.....	10
Figure 9	D-Corvus with Single trace capture.....	13

1 D-Corvus Introduction

This document covers MIL-STD-1553 bus testing procedures using the DragoonITCN D-Corvus and the Corvus test systems. This equipment is used to locate potential 1553 bus problems.

1.1 System Description

The D-Corvus is design for testing and debugging an inactive MIL-STD-1553 data bus. The bus under test must be powered down. The D-Corvus system is comprised of two units and associated interconnect cables. The D-Corvus system is designed to be controlled and used in conjunction with a Corvus unit. The Corvus unit runs the application software and controls the D-Corvus Rx unit.

One of the D-Corvus units is called the D-Corvus TX unit, and it functions as a source of 1553 like data pattern. This data is used to stimulate the bus under test. The Tx unit is connected to any bus stub where its data is distributed across the bus and can be received by all other bus stubs.

The other unit is called the D-Corvus Rx unit, and it is connected to various 1553 bus stubs where it receives the pattern of 1553 data from the transmit unit.

By connecting the Tx unit and Rx unit to various bus stubs the bus can be tested for proper signal loss, polarity and bit errors count. Using the two D-Corvus units a 1553 bus problem is quickly isolated to the stub, coupler, or section of main bus where the problem exists.

Key Features

- Insertion loss measurement
- Signal polarity
- Bit error measurement
- Digital Oscilloscope display
- Battery Powered

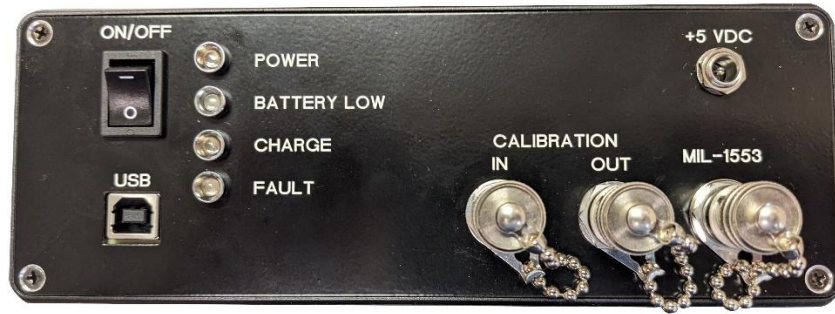

Figure 1 D-Corvus Tx & Rx Box Front Panel

P/N	Name	Description
06-09987	Tx unit	Unit used to transmit 1553 pattern data for test.
06-09988	Rx unit	Unit used to receive 1553 pattern data and measure loss.
05-10075	USB Y Cable	Splits Corvus keyboard port for keyboard and Rx unit Connection.
05-10071	USB Rx Cable	USB type a to USB type B cable assembly for D-Corvus Rx unit.

1.2 Aircraft Bus testing

Before connecting the D-Corvus system to the Aircraft bus make sure the bus is in a powered down state. This requires the bus controller and all remote terminals be in the powered down state. The D-Corvus is designed to connect to the 1553 bus through the bus stub connections. One bus stub connection is used to connect the Tx unit and another bus stub connects the Rx unit as shown in Figure 2.

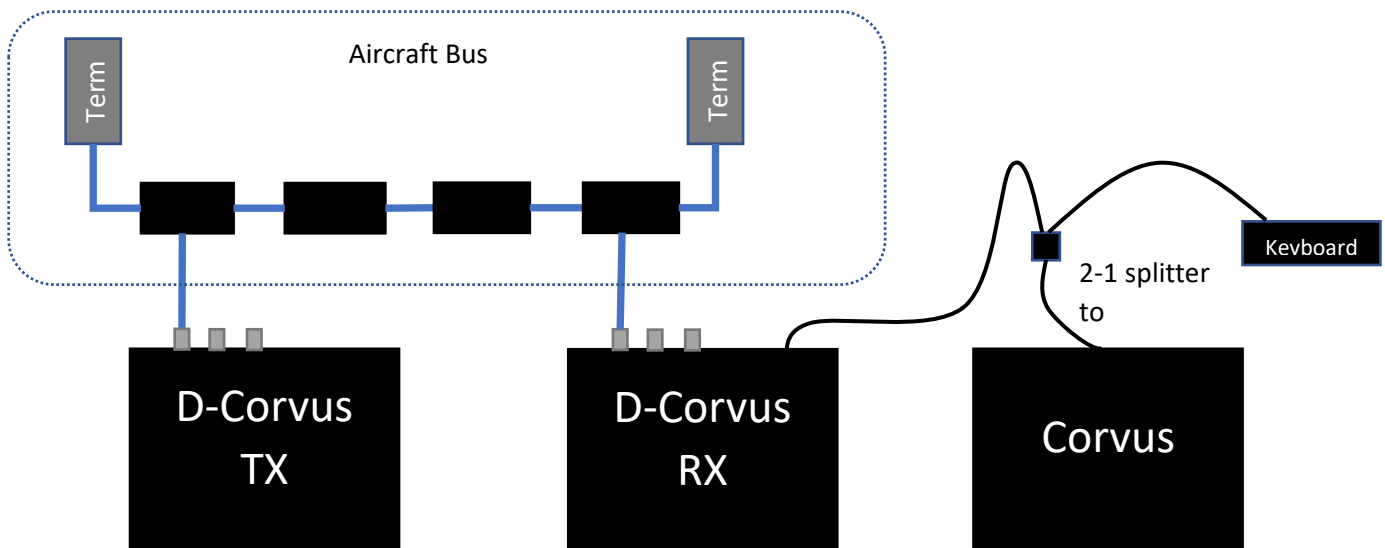

Figure 2 Aircraft Stub Connections

1.2.1 Aircraft Stub Connection

It is often difficult to access the end of the bus stub at the remote terminal (RT). Most RT stub connections are on the rear of the unit requiring removal of the unit to gain access. Remote Terminals have a variety of connector types and pinouts. Adapting the stub connections to a common connector may require many adapter cables. One way to connect to the Stub end is by using pin adapter cables assemblies provided with the Corvus unit. These pin adapter assemblies can be connected to the 1553 Triaxial connection on the Tx unit and Rx unit. The pin adapter end can then be connected to the proper pins on the stub connector.

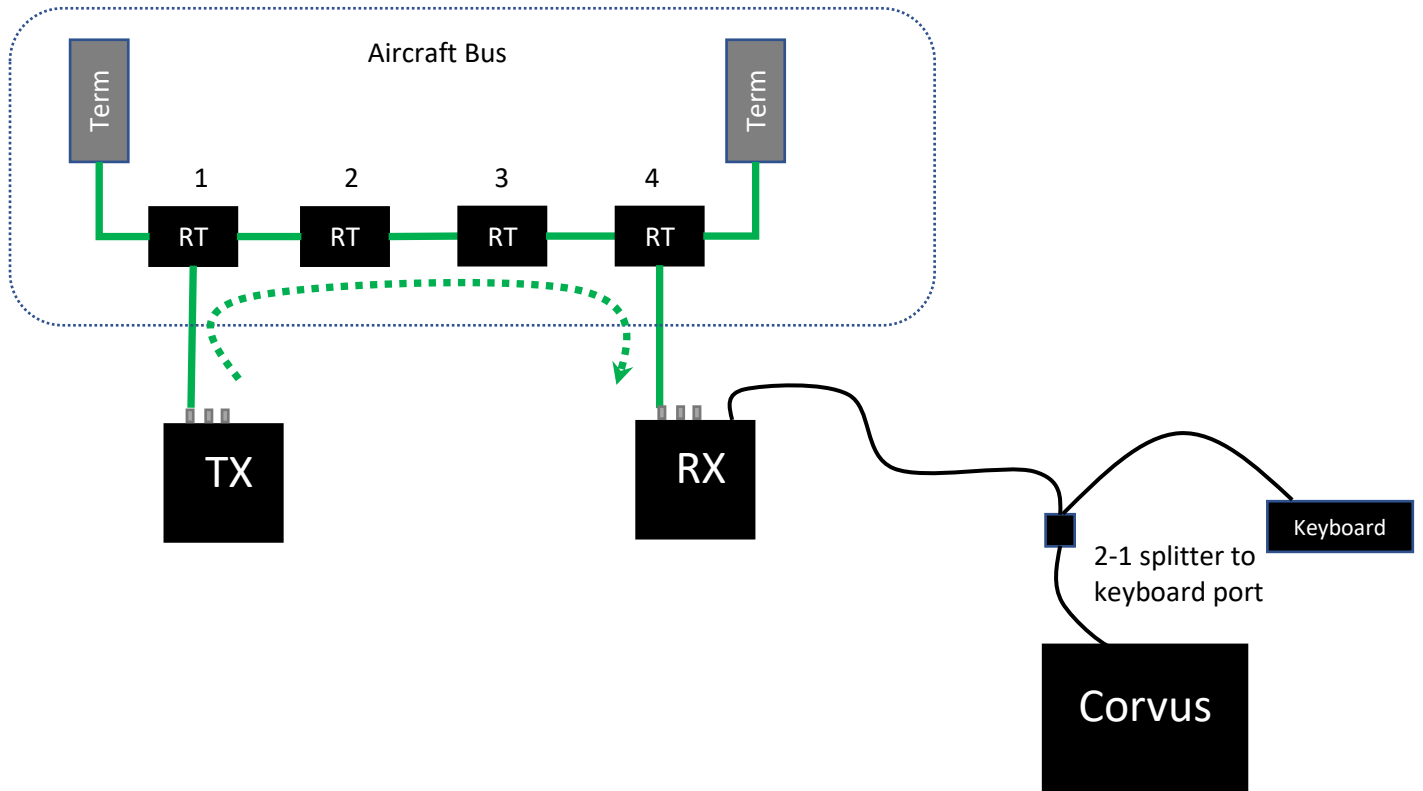

Figure 3 Insertion Loss

Insertion loss is measured for the RT1, RT4 and main bus connections in between as well as terminator connections. Typical Insertion loss is 12dB.

2 D-Corvus Test Procedures

2.1 Calibration

The D-Corvus system requires calibrated before use if insertion loss measurements are to be made. The following procedure calibrates out the lead cables to zero the Rx unit for accurate insertion loss measurements. This must be done before an insertion loss measurement is enabled on in the D-Corvus application.

2.1.1 Calibration setup

1. Connect the Tx unit to the Rx unit as shown in Figure 4. Using the lead cable assemblies provided for connection to the aircraft.

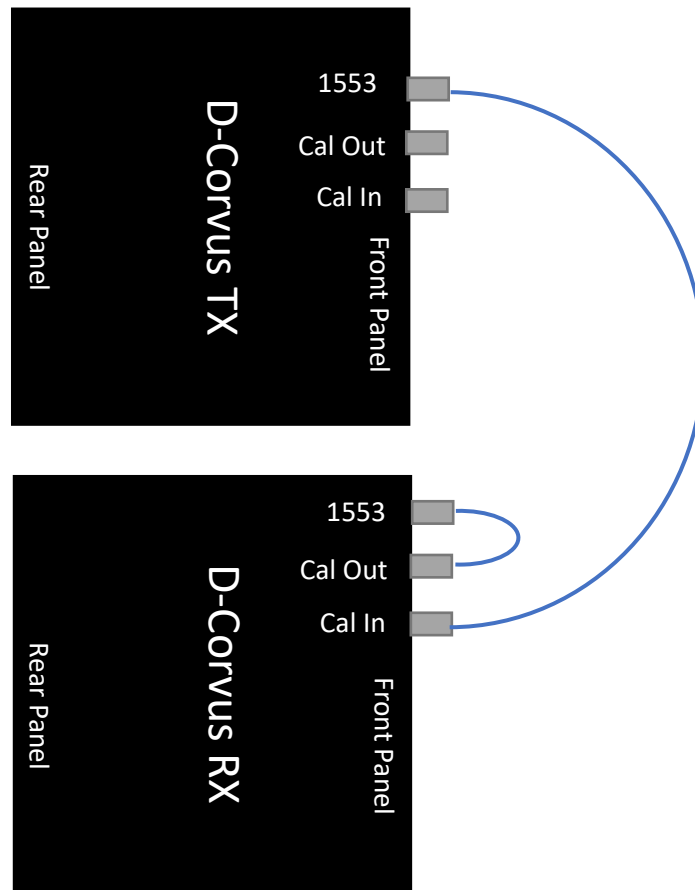

Figure 4 D-Corvus Calibration Connections

2. Connect the D-Corvus Rx unit USB port on the rear panel of the Rx unit to the Corvus unit Keyboard port. The D-Corvus software can be operated with the built in touch screen however some functions may be easier with the keyboard and mouse. To use the keyboard, use the supplied 1-2 USB Splitter cable to connect both the Rx unit and the keyboard to the Corvus keyboard port.



Figure 5 USB Splitter

3. Apply Power to the Corvus unit. The Corvus must either be powered from its power supply or 28 VDC battery.
4. Apply power to the D-Corvus Tx unit by switching the power switch to the on position. The Power LED should illuminate.
5. Apply power to the Rx unit by switching the power switch to the on position. The power LED should illuminate.
6. When the Corvus has completed its boot cycle the Corvus main menu is displayed. select the D-Corvus application.

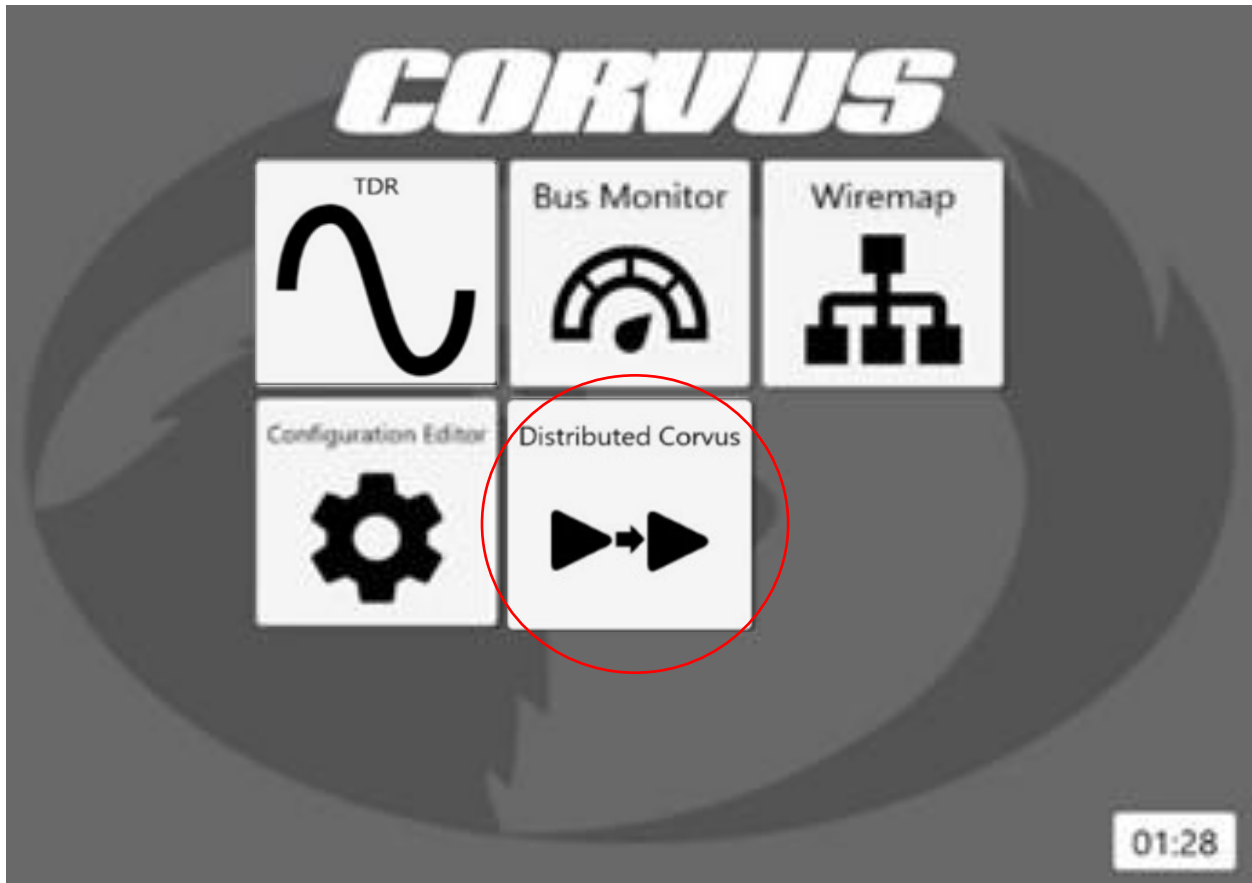

Figure 6 D-Corvus Icon



Figure 7 D-Corvus Application User Interface

7. Select the calibration button as shown. The D-Corvus system calibrates out the test cables and is ready to make insertion loss measurements. The user interface will indicate Calibrated when complete. If calibration fails, some possible causes are loose lead cable connection and/ or failed lead cable. Check connections and retry.
8. The D-Corvus is now ready for bus testing. Disconnect the lead cables from the Rx unit calibration connectors and connect to the bus stubs desired for test.

Note: if power to the Rx unit or the Corvus is lost the calibration procedure must be performed once again. User interface will indicate “Not Calibrated” and insertion loss measurement is disabled.

2.2 Aircraft Test Setup

When calibration is complete the D-Corvus is now ready to test various stub and bus segments. The D-Corvus lead cables should be connected to the Stub via cable adapters or the Pin adapter cables connected to the stub ends.

2.3 D-Corvus Operation

The D-Corvus Tx unit is designed to operate without any user interface or control. The unit begins transmitting its data pattern when power is turned on. The D-Corvus Rx unit must be controlled by the D-Corvus application. This application is installed on the Corvus unit. The Corvus is connected through the key board port via 2-1 USB splitter / hub.

2.3.1 D-Corvus User Interface

After completing the calibration procedure steps from 2.1 Calibration and connecting the D-Corvus Rx and Tx unit to the Cable adapters or pin adapters the D-Corvus application is ready for test.

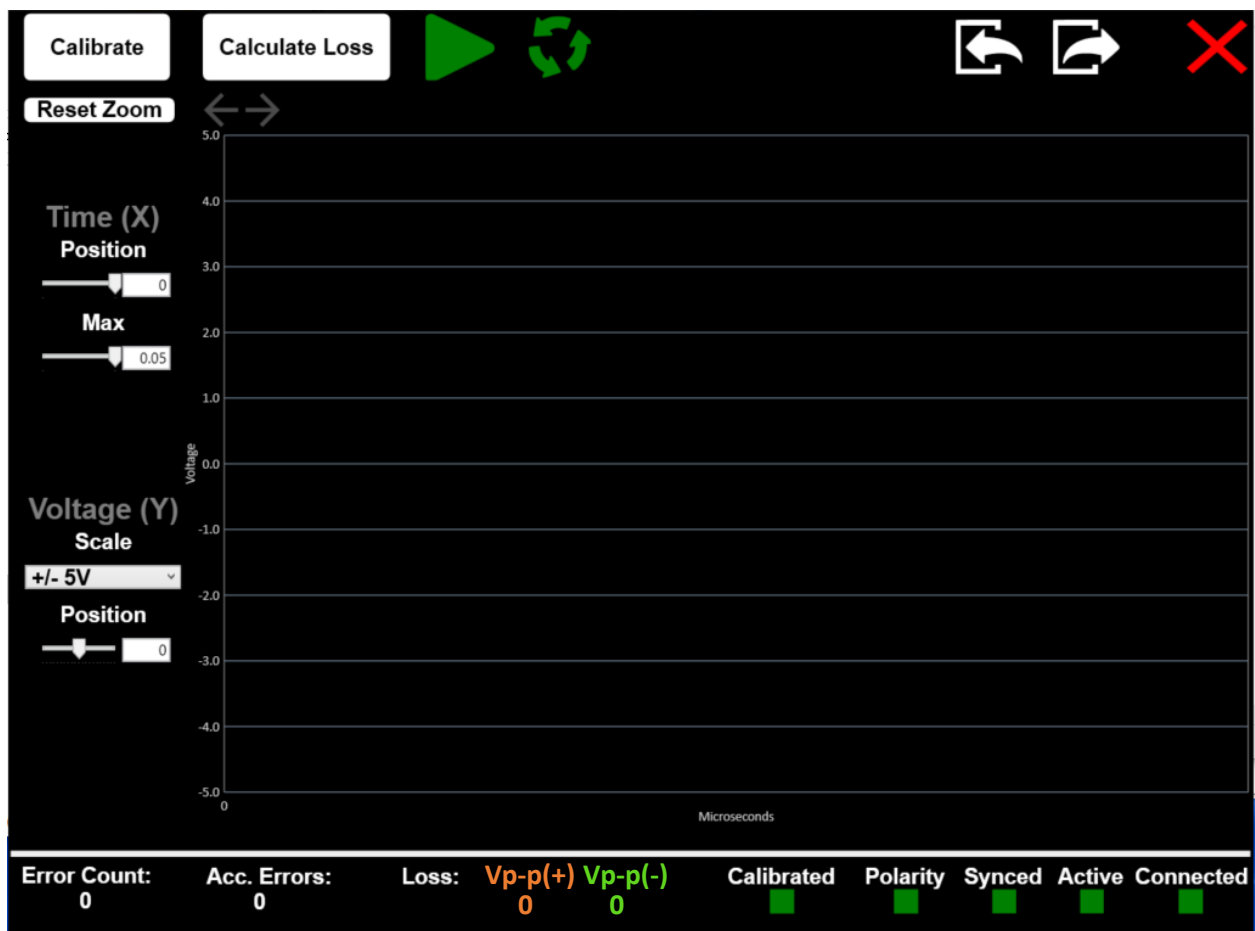

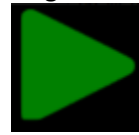



Figure 8 D-CORVUS UI

The bottom of the user interface displays D-Corvus status indications as follows.

Indicator	Description
Error Count	When running continuously and receiving data is synced, the receive unit constantly checks for errors in the data pattern. On a good bus no errors should occur. Any error count greater than 0 indicates poor bus health. If during the collection or error the system loses sync the errors will zero out but will be added to the accumulated error count.
Acc Errors	Acc Errors keep track of errors accumulated during receive analysis of data pattern. A loss of sync resets the error count but not the Acc Errors. This is useful while troubleshooting intermittent connections. Error count is cleared by stopping the continuous run and restarting another continuous run.
Loss	Indicates the signal loss of the Tx unit pattern data going through two couplers, bus segment and stubs. Typical loss is 12dB. This includes bus terminators. A missing bus terminator reduces the signal loss to approximately 9dB indicating a fault. A bad connection or coupler could increase the loss losses greater that 13-14 dB depending on bus under test.
Calibrated	Green Calibrated or Red Not Calibrated If calibrated the Lead cables and D-Corvus units have been normalized to Zero out internal and lead cable loses and is ready to measure insertion lose.
Polarity	Green Polarity Good or Red polarity Swapped If the polarity is swapped the receive unit will never sync. This indicates somewhere in the segment under test the positive and negative data pair has been miss wired or swapped. *When Connected to a live bus disregard this indicator*
Synced	Green Synced or Red Not Synced Synced indicated we are receiving data good enough for the receive unit to sync up to it and start checking for bit errors. If the indicator shows Not Synced, then the data is corrupted to a point we cannot sync to it. *When Connected to a live bus disregard this indicator*
Active	Green Active or Red No Activity Activity when green shows we are seeing some data transitions. No open connections in bus segment under test. If we have no activity, then we have no data received. This needs to be fixed before we can determine error count or sync receive unit.
Connected	Green Connected or Red Disconnected

Connected indicates the Corvus unit is able to communicate the Rx unit. If the status indicates disconnected check the y adapter and USB cable from the Rx unit to the Corvus. The must be connected for any test to be performed.

On the top of the user interface are the following control buttons

Indicator	Description
Calibrate	The Calibrate function is used to calibrate out lead cables assemblies.
Calculate Loss	After calibration and connection to the bus under test the Calculate loss function measures signal loss from stub to stub.
Collect single	Collect and display 1553 data single trace trigger.
	
Collect Data Continuous	Collect and display 1553 data with continuous trace trigger.
	
Import File	Import captured and saved 1553 data trace.
	
Export File	Save a 1553 data trace to file.
	

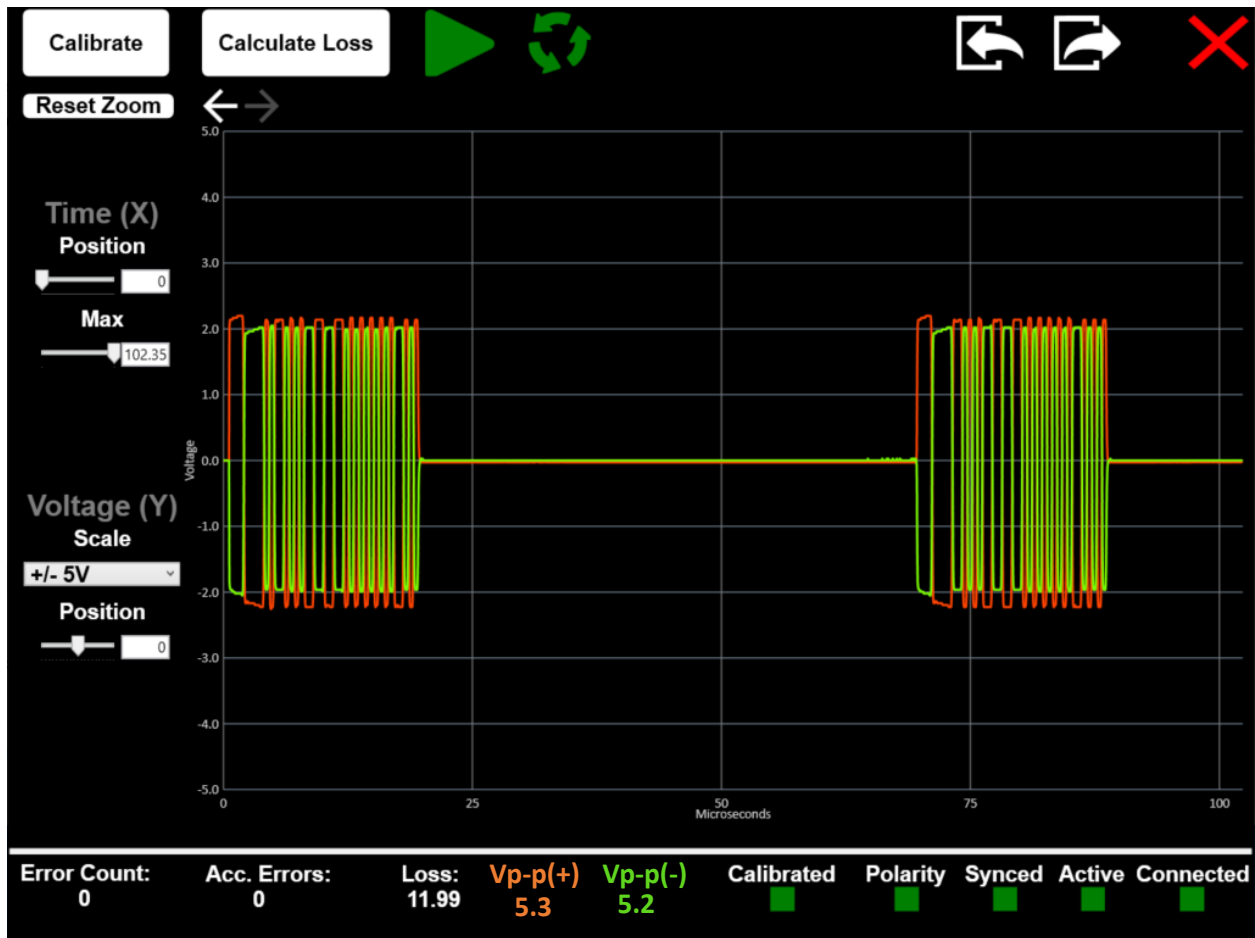

Figure 9 D-Corvus with Single trace capture

3 D-Corvus Power Specifications

3.1 Front Panel Indicators

D-Corvus has four LED indicators for Power and battery status.

Indicator	Description
Power	Green LED to indicate that the unit is powered on.
Battery Low	Green LED that will blink on and off when the Battery is low on charge. When the light is illuminated there is about 10 minutes of run time before the unit will power off.
Charge	Green LED illuminates when the 5V supply is connected to the +5VDC port. <ul style="list-style-type: none"> • To charge the unit the On/Off switch must be in the on position and not be connected to a live bus. • Connect the 5V Power Adapter to the +5VDC port. • A flashing Green LED indicates battery is charging. • A solid Green LED indicates the battery is fully charged and ready to use.
Fault	A solid Red LED indicates there is a battery charging fault. If this Led illuminates, then cycle power by flipping the On/Off switch. If the LED is still illuminated after a power cycle, then contact DragoonITCN Customer Service for support.

3.2 Battery information

D-Corvus uses a widely available rechargeable lithium-ion battery pack. Secondary/replacement battery packs can be made available by contacting DragoonITCN Customer Service.

Description	Rechargeable Battery
Battery Chemistry	Lithium-Ion
Voltage - Rated	3.7V
Capacity	6.27Ah
Standard Run Time	4 Hrs.
Standard Charge Time	8 Hrs.
Cycle Life	Cycle life ≥500